



Health

Certificate of Accreditation

Sewage Management Facility

Aerated Wastewater Treatment System

This Certificate of Accreditation is issued by the Secretary of the NSW Ministry of Health pursuant to Clause 41(1) of the Local Government (General) Regulation 2005.

System: Earthsafe Model ES10PC AWTS

Manufacturer: Earthsafe Environmental Pty Ltd

Of: 6 Marklea Close, Tuggerah, NSW, 2259

The Earthsafe Model ES10PC AWTS as described in Schedule 1, has been accredited as a sewage management facility for use in single domestic premises in NSW. This accreditation is subject to the conditions of accreditation and permitted uses specified in Schedule 2.

*Director, Environmental Health
for Secretary (delegation PH335)*

Issued: 19 September 2015

Certificate No: AWTS 009

Expires: 31 December 2020

Schedule 1: Specification

Earthsafe model ES10PC Aerated Wastewater Treatment System

General Description

The Earthsafe model ES10PC Aerated Wastewater Treatment System (AWTS) is designed to treat the wastewater from a residential dwelling occupied by a maximum of 10 persons. The Earthsafe model ES10PC AWTS is contained in one vertical axis type cylindrical precast concrete collection well with a design capacity of 7100 litres and is manufactured by Central Coast Septics Accreditation no: CofA 015-1485. The operational water level in the aeration chamber of the system is 1650 mm. The system consists of:

- A primary sedimentation chamber with a capacity of 3250 litres;
- A contact aeration chamber with a capacity of 2850 litres and containing two blocks of filter media manufactured by Tapex Pty Ltd and measuring 600 mm long x 540 mm wide x 540 mm high with a surface area of 70 m²;
- A clarifying chamber with a capacity of 460 litres;
- A chlorine contact chamber with a capacity of 165 litres;
- A irrigation pump chamber with a capacity of 165 litres;
- A chlorine disinfection unit installed on the outlet pipe of the clarifier;
- Air is supplied to the contact aeration chamber by a Nitto LA80, Hiblow HP80 or equivalent with an output of 80 litres/minute;
- A submersible irrigation pump selected from the DAB300 (7 metre low head) or DAB600 (11 metre high head) or equivalent.

Schedule 2: Conditions of Accreditation

1.0 General

- 1.1 For each installation the owner/occupier of the premises shall make an application to the local council to install an Earthsafe model ES10PC AWTS as a waste management facility in accordance with Section 68, Part C of the *Local Government Act 1993* and Clause 26 of the *Local Government (General) Regulation 2005*.
- 1.2 The Earthsafe model ES10PC AWTS shall be supplied, constructed and installed in accordance with the design as submitted and accredited by the NSW Ministry of Health.
- 1.3 Any modification or variations to the accredited design of the Earthsafe model ES10PC AWTS shall be submitted for separate consideration and variation of the Certificate of Accreditation by the Secretary of the NSW Ministry of Health.
- 1.4 Each Earthsafe model ES10PC AWTS shall be permanently and legibly marked on a non-corrosive metal plaque or equivalent, attached to the lid with the following information:
 - The brand name of the system;
 - The manufacturer's name or registered trademark;
 - The month and year of manufacture.
- 1.5 The manufacturer shall supply with each Earthsafe model ES10PC AWTS an owner's manual, which sets out the care, operation, maintenance and on-going management requirements of the system.

- 1.6 The manufacturer shall provide the following information to each local authority where it is intended to install an AWTS in their area once Ministry accreditation has been obtained:
- Statement of warranty
 - Statement of service life
 - Quality Assurance Certification
 - Installation Manual
 - Service Manual
 - Owner's Manual
 - Service Report Form
 - Engineering Drawings on A3 format
 - Detailed Specifications
 - A4 Plans
 - Accreditation documentation from NSW Health.

2.0 Installation and Commissioning

- 2.1 The local council should require that on completion of the installation of the Earthsafe model ES10PC AWTS, the system is inspected and checked by the manufacturer or the manufacturer's agent. The manufacturer or the agent is to certify that the system has been installed and commissioned in accordance with its design, conditions of accreditation and any additional requirements of the local council.
- 2.2 The local council should require that all electrical work must be carried out by a licensed electrician and in accordance with the relevant provisions of AS/NZS 3000.

3.0 Maintenance

- 3.1 The local authority shall require the owner/occupier of the premises to enter into an annual service contract with a representative of Earthsafe Australia Pty Ltd or a service contractor or company acceptable to the local council.
- 3.2 The Earthsafe model ES10PC AWTS shall be serviced at three monthly intervals in accordance with the details set out in the owner's and service manual.
- 3.3 Each three monthly service shall include a check on all mechanical, electrical and functioning parts of the system including:
- The chlorinator and replenishment of the disinfectant,
 - Pumps, air blower, fan or air venturi,
 - The alarm system,
 - Slime growth on the filter media,
 - Operation of the sludge return system,
 - The effluent irrigation area,
 - On-site testing for free residual chlorine, pH and dissolved oxygen.
- 3.4 The local council should require that a service report sheet, in triplicate, is completed for each service. The original shall be given to the owner, the duplicate forwarded to the local council and the triplicate retained by the service contractor.

4.0 On-going Management

- 4.1 The owner's manual prepared by the manufacturer shall contain a plan for the on-going management of the Earthsafe model ES10PC AWTS. The plan shall include details of:
- the treatment process,
 - procedures to be followed in the event of a system failure,
 - emergency contact numbers,
 - maintenance requirements,
 - inspection and sampling procedures to be followed as part of the on-going monitoring program developed by the local authority.
- 4.2 Effluent from the Earthsafe model ES10PC AWTS taken in any random grab sample shall comply with the following standard:
- BOD⁵ less than 30 mg/L
 - TSS less than 45 mg/L
 - E. coli less than 100 cfu/100 ml
 - Free residual chlorine greater than 0.5 and less than 2.0 mg/L

5.0 Permitted uses

- 5.1 The effluent is suitable for re-use for garden purposes by way of any of the forms of irrigation as described in AS/NZS 1547:2012:
- above ground spray irrigation; or
 - surface drip irrigation covered by mulch; or
 - sub-surface drip irrigation installed at around 100 mm depth.

Each of the three forms of irrigation is subject to the approval of the local council.



**EarthSAFE
Environmental**

ABN: 93 115 940 700
PO Box 605 Wyong 2259
Ph: 1 300 327 847
F: 02 43534113

6 Marlea Close
Tuggerah 2259
NSW

Designed; SF

Date; 2006

Lic; 188794C

SITE;

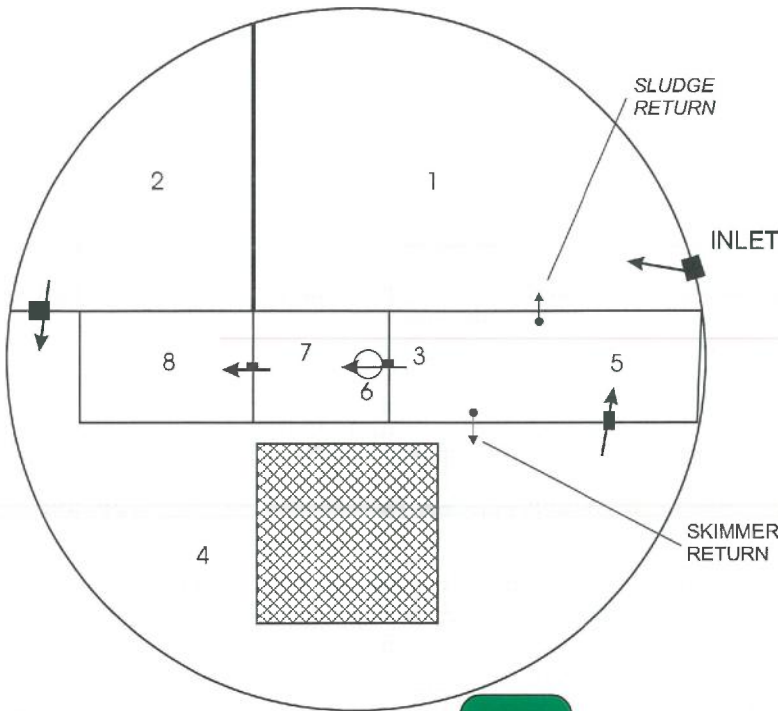

LEGEND;

Treatment Process

1. 2/3 PRIMARY TREATMENT
2. 1/3 PRIMARY TREATMENT
Minimum 3247lt
3. SURGE REDUCTION
4. AERATION
Minimum 2852lt
5. CLARIFIER
Minimum 460lt
6. CHLORINATOR
7. CHLORINE RETENTION
Minimum 165lt
8. PUMP WELL
Minimum 165lt

APPROVED

1 9 SEP 2016

NSW MINISTRY OF HEALTH

GREEN BOX

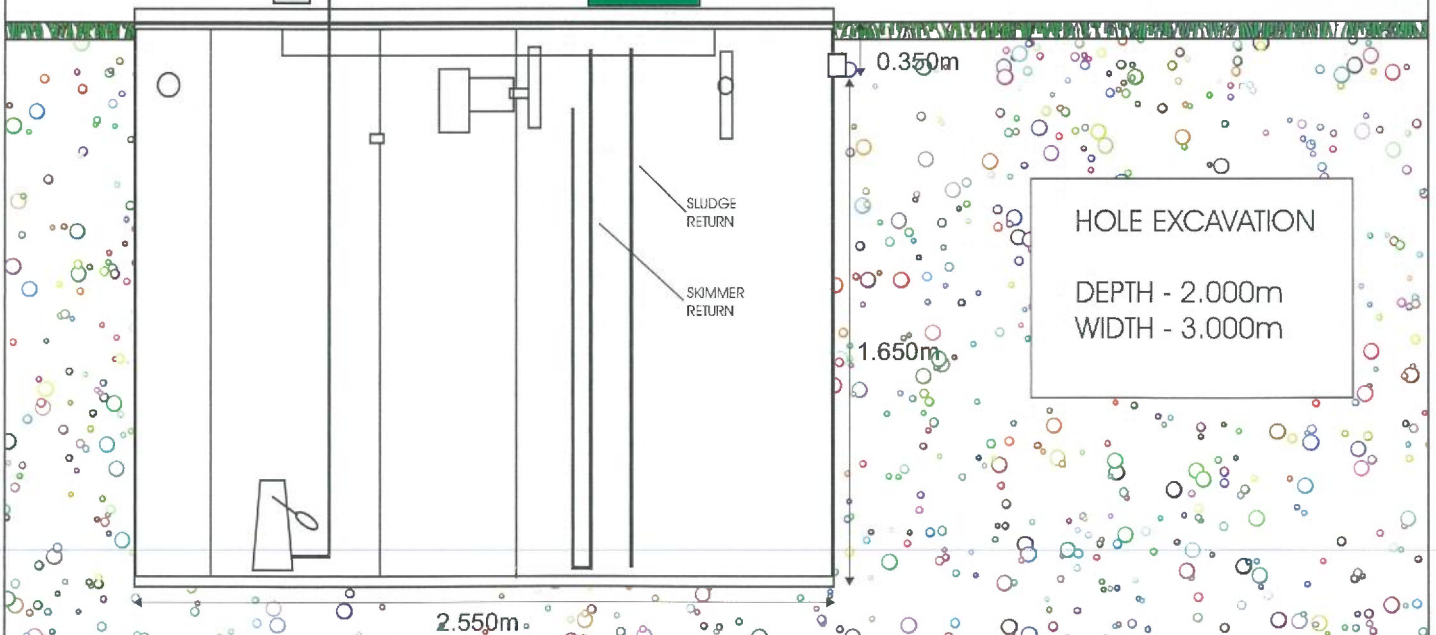

NOTE:

ALL TANKS TO COMPLY WITH AS 1546.1 ALL PVC FITTINGS TO COMPLY WITH AS 1477
SYSTEM DESIGN BY EARTHSafe NEWCASTLE PTY LTD

TANK MANUFACTURE:

CENTRAL COAST SEPTICS ■ GRAHAMS CONCRETE KYOGLE ■